

# QUALITY CONTROL EQUIPMENT CORP. **Fish Cleaning Station**

## Overview

The QCEC Fish Cleaning Station is the most efficient fish cleaning station available. It turns fish waste into small particles - easily flushed away. The self-contained unit uses a powerful Muffin Monster® dual shafted grinder to shred solids, such as fish parts, cans, plates, utensils and fishing lures. This prevents clogging and protects downstream equipment. The QCEC Fish Cleaning Station is clean, cost effective and reliable.

## For Parks, Piers or Marinas



*A Fish Cleaning Station at a Michigan park.*

The QCEC Fish Cleaning Station is an excellent way to provide a pleasant park experience for residents and visitors. Fishermen enjoy the ease and convenience of our Fish Cleaning Station. And best of all, long lasting Monster equipment is reliable, and requires little maintenance. Grind it up, flush it down!



*The Muffin Monster's steel cutters are more reliable than a garbage disposal.*

## Features & Benefits

### Ease and Flexibility of Installation

- Complete system — pre-plumbed and pre-wired. Install indoors or outdoors. Optional lockable winter cover.
- Designed to be accessible, meets A.D.A. Standards.

### Muffin Monster® Grinder

- Dual-shafted grinder reduces solids to small particles to prevent clogging and protect downstream equipment.
- Two powerful banks of cutters grab and shred fish parts, beer cans, plastic utensils, weights, line and more.
- Low speed operation results in higher torque and less interrupts. Pull-out stand for easy grinder access.

### Spray Wash System

- Two 3' spray wands with easy reach cords. Five programmable swirlspray nozzles. Meets the highest standards of National Sanitation Foundation®.

### Cutting Boards

- Stain-resistant, self draining polyethylene cutting boards are provided on both sides of the table.

### Inlet Safety Guard

- Sized for safety and prevention of user access to the grinder.

### Automated Control Panel

- Start, stop and timer system accessible from either end of table.
- Jam prevention system: grinder will stop, reverse rotation of cutters then resume forward rotation. If the object does not pass through unit, an alarm will illuminate or sound indicating maintenance is required.



# Fish Cleaning Station

## Operation

- 1) User presses the 'Start' button and the grinder and spray wash system activate for a pre-programmed length of time
- 2) Wet or dry solids enter the Muffin Monster® dual-shafted grinder via the inlet.
- 3) Solids pass through the cutters and are reduced to a small particle size.
- 4) The ground material is flushed into the local sewer system. Solids pose no threat downstream pumps.

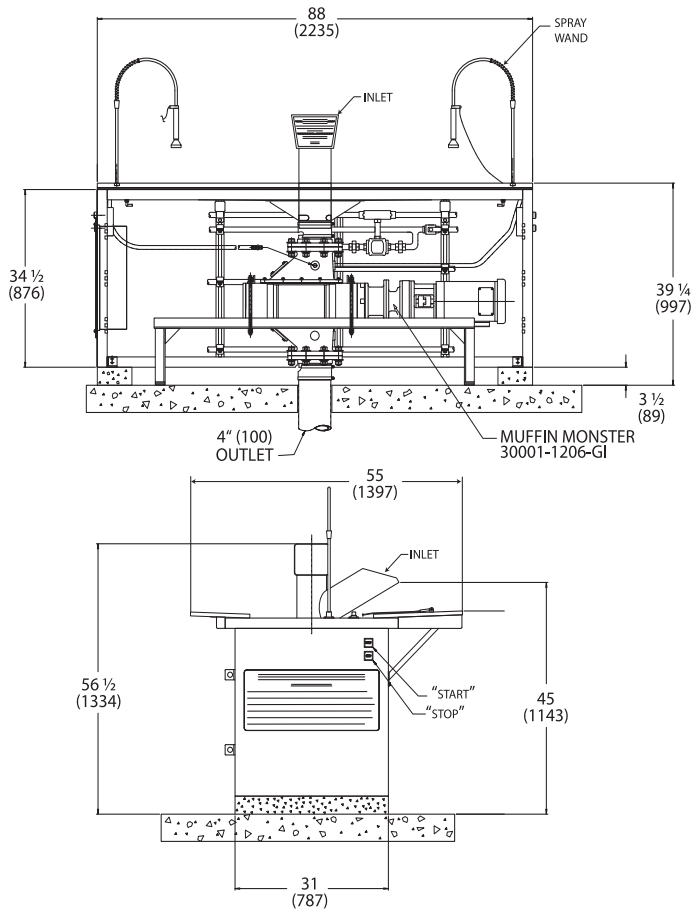
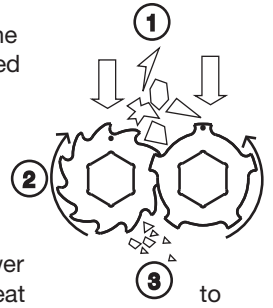

## Materials of Construction

**Table:** 14-gauge stainless steel. 84"l x 43"w x 38"h

**Grinder Cutters:** Heat treated alloy steel, surface ground for uniformity and through-hardened.

**Seal Faces:** Tungsten carbide / tungsten carbide.

**Plumbing Includes:** Pressure type vacuum breaker, solenoid actuated water valve and shut-off valve.

**Freeze Protection:** Heat wrapped copper plumbing and lockable steel winter cover.



*Specially designed three tooth cutters are used with the Fish Cleaning Station.*



Proudly manufactured by  
**Quality Control Equipment Company**  
 4280 E. 14th Street  
 Des Moines, IA 50313  
 p: 515-266-2268  
 f: 515-266-0243  
 e: sales@qcec.com



[www.QCEC.com](http://www.QCEC.com)